

**POOL RECOMMENDATIONS**

Recommended Minimum Pool Area Reserved For Slide Operation Is 10' x 20' With Minimum Water Depth Of 42"

**BASE SPECIFICATIONS**

Ride Length 35.57'  
 Centerline Length 31.73'  
 Starting Elevation 5'-6"  
 Slope 19.04%  
 Flume Width 32.00"  
 Centerline Radius 6'-0"  
 Designed Water Flow 200 GPM

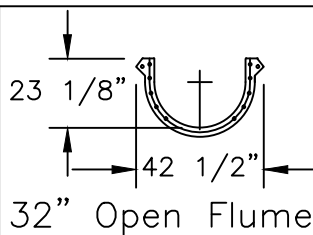

**MIRROR MODEL: PS36L-S**

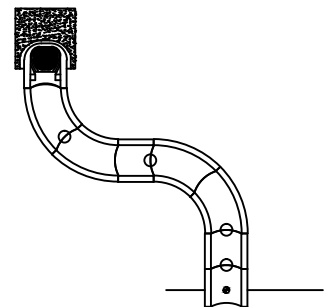

CONFIDENTIAL – PROPERTY OF Paradise Slides, Inc.

<b>Paradise Slides, Inc</b>		Standard Model PS36R-S	
295 Singing Tree Ln. – Cleveland GA 30528		DWG SCALE 1/8" = 1'-0"	DRAWN BY TCP
Phone (706)865-4849 Fax (706)865-4890		REVISION 0	DWG. DATE April 14th, 2012
		REVISION DATE --- --, ---	DWG. NO. PS36R-S